

EVOLVING TO BETTER THINGS

HONEYWELL EVO

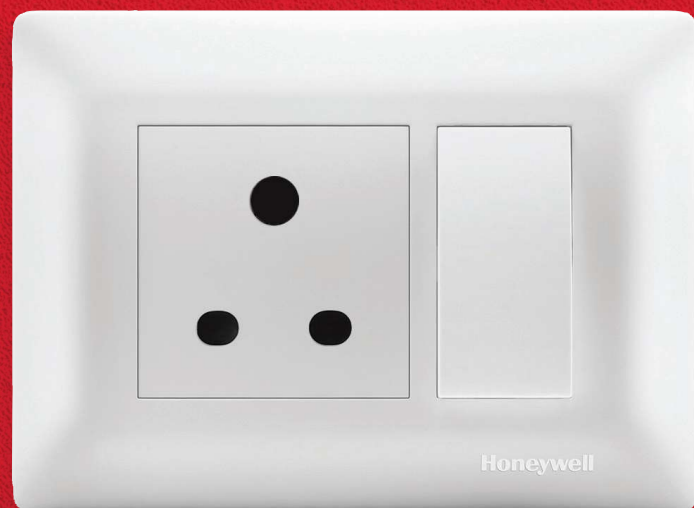

Honeywell

**WE
GIVE YOU
THE
BEST
OF EVOLUTION**



HONEYWELL EVO

Evolving to
Better Things

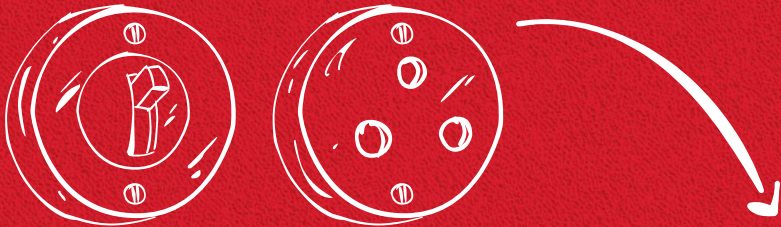

Change is the
only constant.
At Honeywell,
we have taken
Change head on to
become the Masters
to provide ever
Evolving Wiring
Devices Solutions.

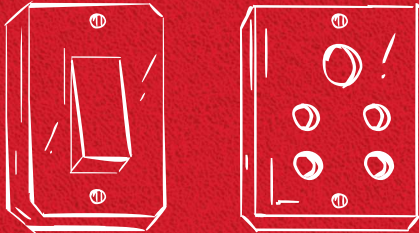

We continuously
strive to better our
products with time
as technology
Evolves. And in this
quest, we give you
the perfect blend
of quality, price
and performance.

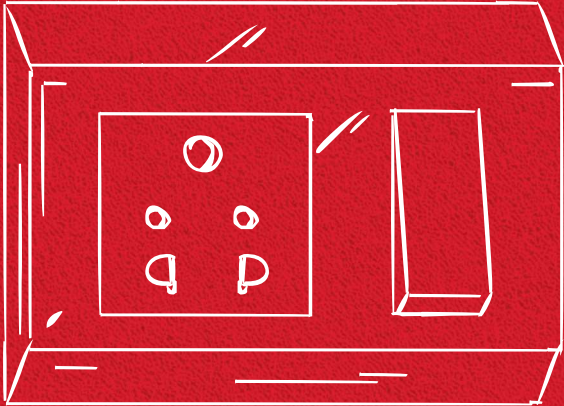

**SLEEK
PLATES
& GLOSSY
FINISH**



AESTHETICS

HONEYWELL EVO

Evolving to
Better Things



PREMIUM GLOSSY FINISH

Evolution does not mean you leave behind aesthetics. Thus, every inch of the Honeywell Evo Wiring Devices range has a premium glossy finish to amplify your home décor.



SLEEK PLATES

Smart design is a key feature of Evolution. Honeywell Evo wiring device range boasts of Sleek Front Plates and a Curved Body. Such a unique form reduces dust deposition and ensures that you don't have to keep cleaning it time and again.



COLLARLESS MODULAR DESIGN

We have gone one step beyond the ordinary blueprint of regular switches to craft Honeywell Evo. The secret to Honeywell Evo's superior looks is its Collarless Modular Design that truly sets it apart in its segment.



WIDE ROCKER DESIGN

Wide Rocker complements aesthetics and provides enhanced operating experience thus giving a convenient interface to user.



**SAFE &
STURDY**

PERFORMANCE

HONEYWELL EVO

Evolving to
Better Things



TESTED UPTO 1 LAKH OPERATIONS

Upgradation should ensure a longer life span. Honeywell Evo's enhanced Durability is not just a claim – it has been proved after being Tested for upto 1 Lakh Operations.



SHOCK PROOF IP20

What is the point of advanced tech, if it's not safe? We have, thus, ingrained Shock Proof IP20 in our new Honeywell Evo Range, to ensure that the terminals are finger proof and prevent shocks.



SAFETY

We take safety very seriously – not just of our users, but of everyone who might come in contact with our product. Honeywell Evo comes with Shuttered Sockets that prevents accidental contact with live parts, while also preventing dust deposition.



ISI CERTIFIED

Choosing advanced electrical goods means buying into the promise of better products. Our superior standard of quality has not gone unnoticed. Honeywell Evo **Switches, Sockets and Fan Speed Controller** are BIS approved and have ISI certification.



**EASE OF
OPERATION**

CONVENIENCE

HONEYWELL EVO

Evolving to
Better Things



EASY INSTALLATION

Installation and modification should not scare you away anymore. We have evolved the regular system such that with Honeywell Evo's Front Loading and Removal of Accessories, you don't have to unscrew the grid plate – just remove the accessory, do the changes and re-install !



BIS APPROVED USB CHARGER

Providing convenience to our customers has been focal point of Honeywell Evo. Hence we have BIS Approved (IS 13252(Part 1):2010 / IEC60950-1:2005) 2.1A 1Module USB Charger which gives you the convenience to charge your latest gadgets without the hassle of an adapter.



USER EXPERIENCE

We believe in hassle-free operations, and the structure of Honeywell Evo exhibits just that. All the Accessories of Honeywell Evo range has a Firm Grip on plug's with uniform insertion and withdrawal force to provide a stellar user experience.

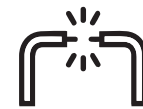

CAPTIVE SCREW TERMINALS

No matter who is in-charge of installation, with Honeywell Evo, it is an effortless experience. Honeywell Evo's Captive Screw Terminals avoids slippage and facilitates faster and safer wiring.



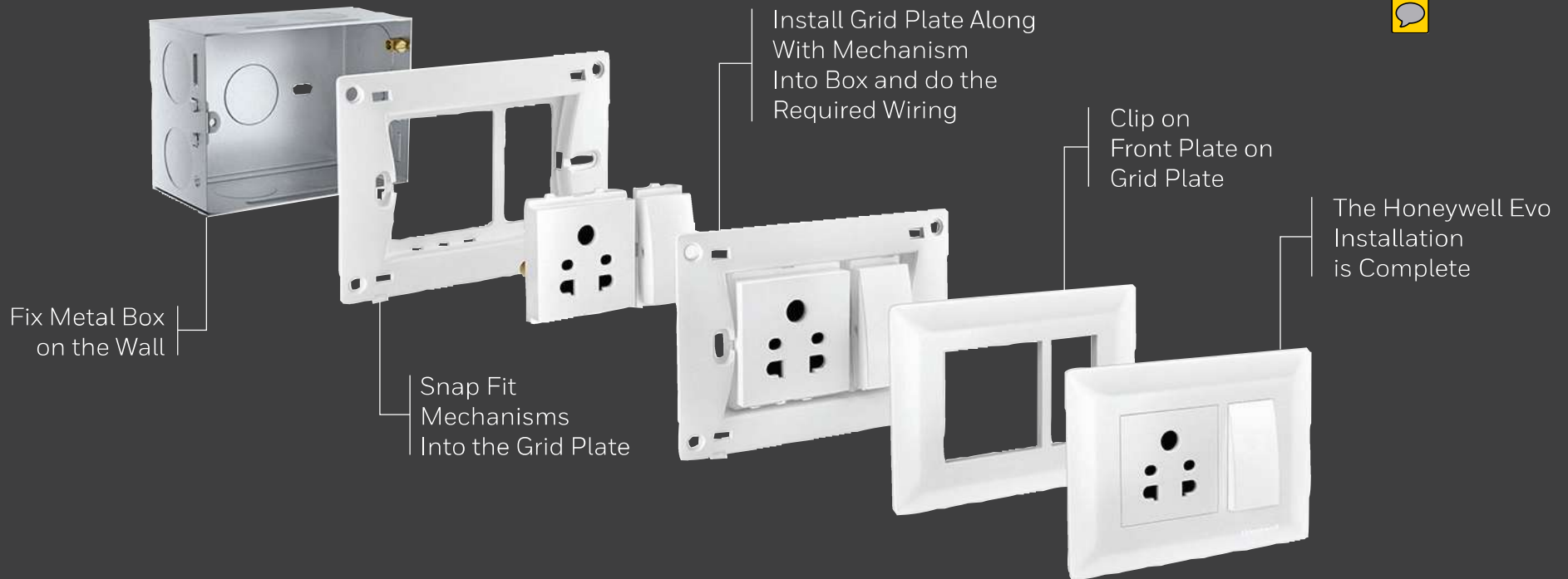

INSTALLATION PROCESS



HONEYWELL EVO WIRING DEVICES

HONEYWELL EVO
Evolving to
Better Things

SWITCHES - WHITE

	ItemCode	Description	Module	Carton Qty.*
 EW501WHI	EW501WHI	6AX One Way Switch	1M	20 / 360
	EW502WHI	6AX Two Way Switch	1M	20 / 360
 EW502WHI	EW503WHI	6AX One Way Switch with Indicator	1M	20 / 360
	EW411WHI	16AX One Way Switch	1M	20 / 360
 EW224WHI	EW412WHI	16AX Two Way Switch	1M	20 / 360
	EW413WHI	16AX One Way Switch with Indicator	1M	20 / 360
 EW505WHI	EW220WHI	25A SP One Way Switch with Indicator	1M	20 / 360
	EW224WHI	32A DP Switch with Indicator	2M	12 / 216
	EW505WHI	6A Bell Push Switch	1M	20 / 360
	EW504WHI	6A Bell Push Switch With Indicator	2M	12 / 216

SOCKETS - WHITE

	ItemCode	Description	Module	Carton Qty.*
 EW426WHI	EW420WHI	6A Universal Socket	2M	12 / 216
	EW421WHI	6A Round Pin Socket (ISI Marked)	2M	12 / 216
	EW424WHI	6/16A Socket (ISI Marked)	2M	12 / 216
	EW426WHI	International Socket For 6/10/13A	2M	12 / 216
	EW425WHI	25A Socket	2M	12 / 216

FAN REGULATOR & DIMMER - WHITE

	ItemCode	Description	Module	Carton Qty.*
 EW471WHI	EW471WHI	100W 4 Step Fan Step Controller (ISI Marked)	1M	15 / 270
	EW472WHI	120W 5 Step Fan Step Controller (ISI Marked)	2M	10 / 180
	EW480WHI	400W Dimmer	2M	10 / 180

MINI TRIP MCB & MOTOR STARTER - WHITE



	ItemCode	Description	Module	Carton Qty.*
 EW227WHI	EW217WHI	25A Motor Starter	2M	6 / 90
	EW227WHI	25A SP Mini Trip MCB	1M	12 / 180
	EW228WHI	25A DP Mini Trip MCB	2M	6 / 90

COMMUNICATION ACCESSORIES - WHITE



	ItemCode	Description	Module	Carton Qty.*
 EW490WHI	EW493WHI	RJ45 CAT 6A	1M	20 / 360
	EW491WHI	RJ45 Receptor	1M	20 / 360
	EW490WHI	RJ11 2 Line with Shutter	1M	20 / 360

HONEYWELL EVO WIRING DEVICES

SUPPORT ACCESSORIES - WHITE

	ItemCode	Description	Module	Carton Qty.*
 EW441WHI	EW441WHI	Blank Plate	1M	20 / 360
	EW462WHI	TV Cable Outlet	1M	20 / 160
	EW451WHI	TV Coaxial Socket	1M	20 / 160
 EW586WHI	EW595WHI	Red Neon Indicator	1M	20 / 160
	EW530WHI	LED Foot Lamp	2M	10 / 180
	EW586WHI	2.1A 1 Port USB Charger	1M	20 / 360
	EW422WHI	Power Unit (6/16 Socket + 32A DP Switch)	4M	1 / 5

FRONT PLATES - WHITE

	ItemCode	Description	Module	Carton Qty.*
 EW101WHI	EW101WHI	1 Module Front Plate	1M	10 / 180
	EW102WHI	2 Module Front Plate	2M	10 / 180
	EW103WHI	3 Module Front Plate	3M	8 / 144
	EW104WHI	4 Module Front Plate	4M	8 / 144
 EW104WHI	EW106WHI	6 Module Front Plate	6M	8 / 80
	EW18HWHI	8 Module Horizontal Front Plate	8M (H)	4 / 72
	EW18VWHI	8 Module Square Front Plate	8M (S)	4 / 64
 EW112WHI	EW112WHI	12 Module Front Plate	12M	4 / 40
	EW116WHI	16 Module Front Plate	16M	4 / 40
	EW118WHI	18 Module Front Plate	18M	3 / 21

FRONT PLATES

DIMENSIONS

HONEYWELL EVO

Evolving to
Better Things

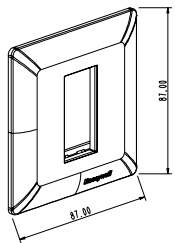

1M

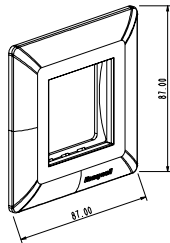

2M

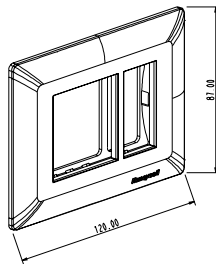

3M

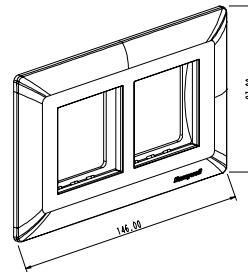

4M

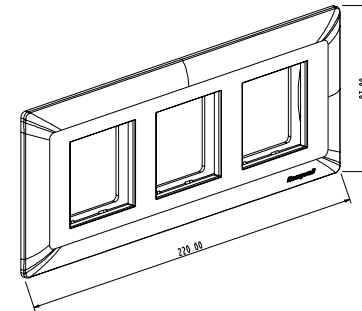

6M

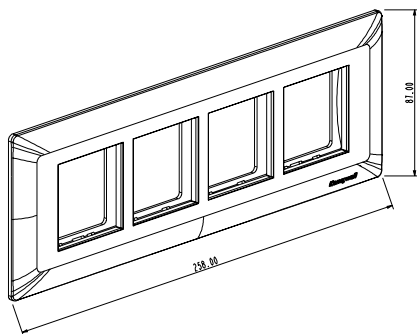

8M (H)

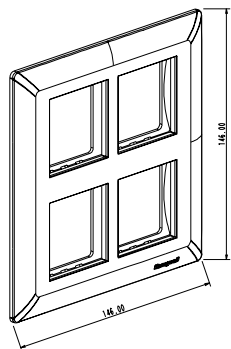

8M (S)

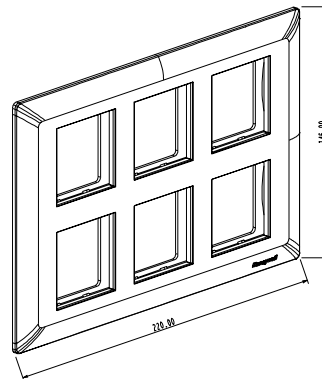

12M

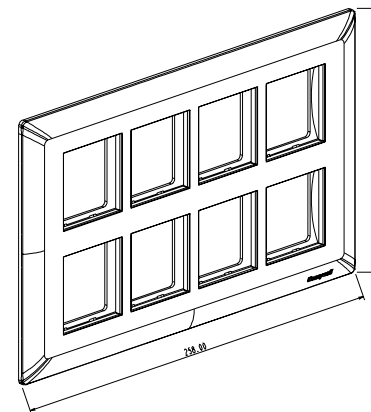

16M

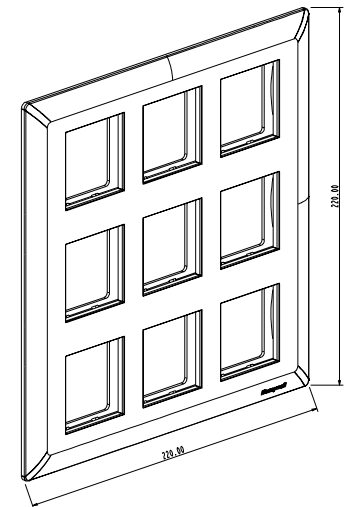

18M

All dimensions are in mm.

METAL BOXES

DIMENSIONS

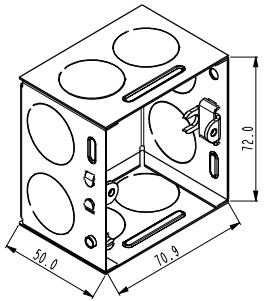

1M & 2M

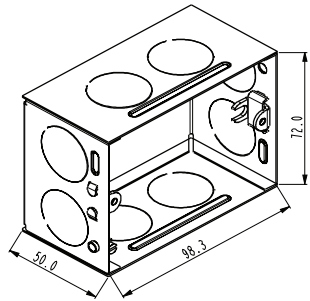

3M

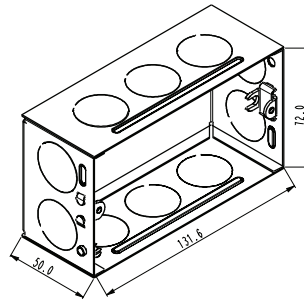

4M

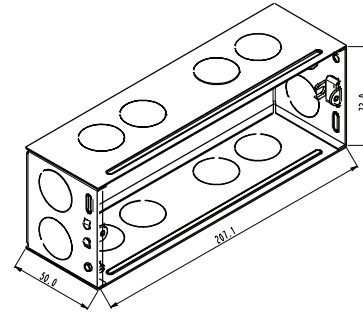

6M

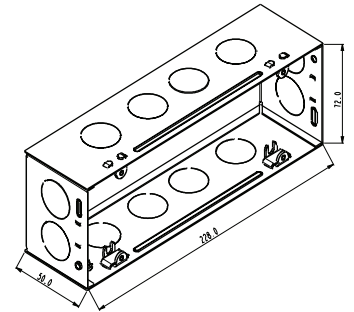

8M (H)

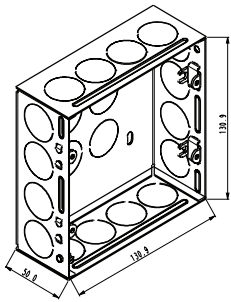

8M (S)

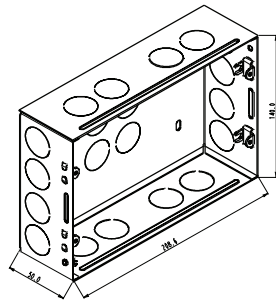

12M

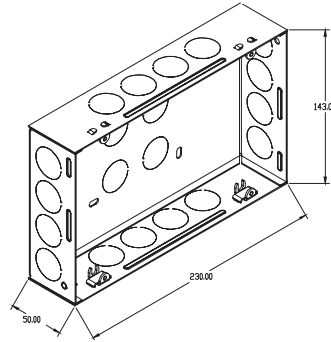

16M

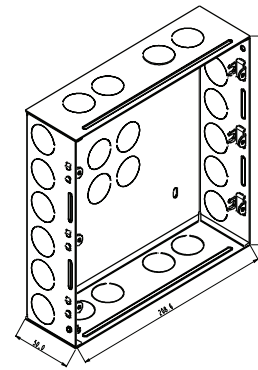

18M

All dimensions are in mm.

PLASTIC SURFACE BOXES

DIMENSIONS

HONEYWELL EVO

Evolving to
Better Things

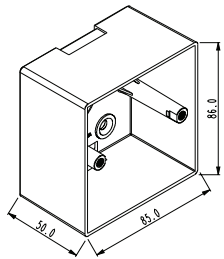

1M & 2M

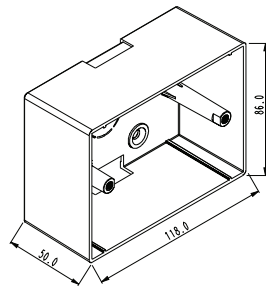

3M

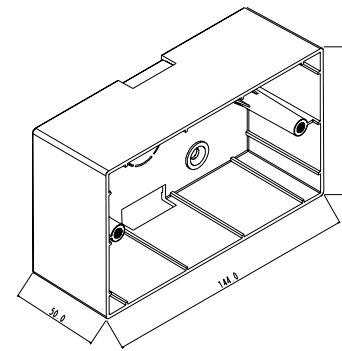

4M

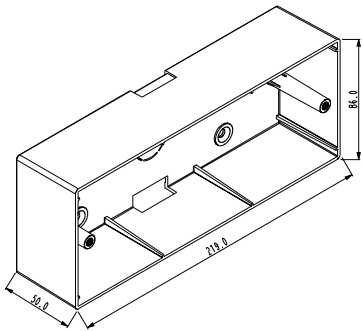

6M

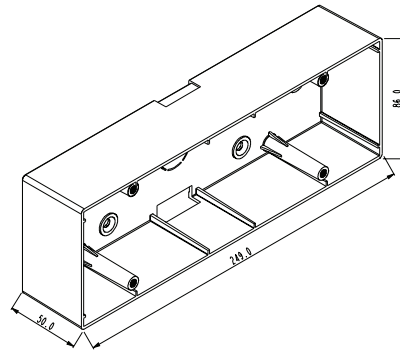

8M

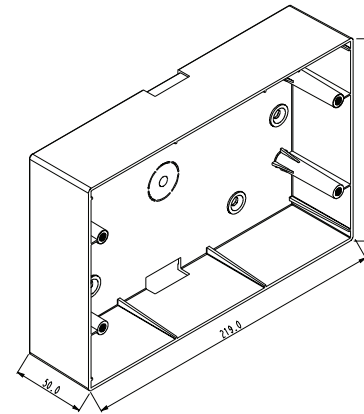

12M

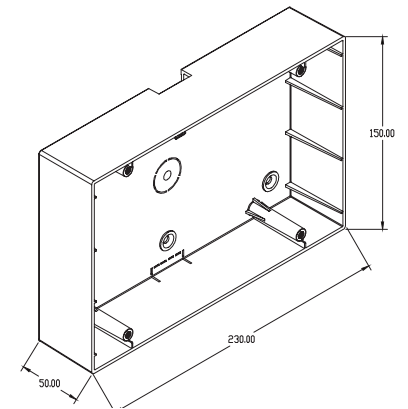

16M

All dimensions are in mm.

GURUGRAM

Unitech Trade Center,
5th Floor, Sector 43, Block C,
Sushant Lok, Phase 1,
Gurgaon - 122 022
Fax: +91-124-6715014

BARODA

Ground Floor, 1965,
Alembic City Avenue, Alembic Campus,
Alembic Road, Vadodara - 390003

PUNE

Plot No. 56/57,
Hadapsar Industrial Estate,
Pune - 411 013
Fax: +91-20-66039800

KOLKATA

Srijan Techpark,
8th Floor, DN-52,
Salt Lake, Sector-V,
Kolkata - 700 091
Fax: +91-33-66283701

BENGALURU

Honeywell Camp II,
Bldgs 9A & 9B, Plot C2, RMZ Ecoworld,
Varturhobli, Sarjapur Marathahalli, Outer
Ring Road, Bengaluru - 560103

CHENNAI

5th, 6th & 7th Floor,
KRM Plaza, North Tower,
#2 Harrington Road,
Chetpet, Chennai - 600031

HYDERABAD

8-2-418, Krishnama House,
3rd Floor, Road No. 7,
Banjara Hills,
Hyderabad - 500 034
Fax: +91-40-66030971

Note: Due to continuous improvement in product design and development,
actual product and color may vary because of printing limitations.

**FOR FURTHER DETAILS,
PLEASE REACH US AT :**

Toll Free Number : 1800-103-3848
Monday to Sunday : 10AM - 7PM
Whatsapp : +91 81306-91299
email : eesteamindia@honeywell.com
website : honeywellsmarthomes.com