

STYLING CHECKED PEACE OF MIND CHECKED

A Perfect Combination of Aesthetics
& Features for a Modern Home



Wiring Devices

#ForStylishSpaces

IMPACT
by Honeywell

WIRING DEVICES

CAPTIVATING LOOKS AND INNOVATIVE FEATURES

Electrical fittings and equipment animate our spaces; with lifestyle options, comfort, and modern conveniences. They define our interactions with our environment, and enhance the aesthetics of built spaces. For a modern home or office to truly represent the finest in what contemporary life has to offer, wiring devices must be elegantly intuitive to use, while also being striking accessories in their own right.

The Impact by Honeywell range of wiring devices excels in both these roles, delivering full-featured functionality and safety at budget-friendly prices that delight customers. These outstanding wiring devices are packed with the latest innovative technologies; while embodying in-vogue, sleek modern stylings, that make a statement.



WIRING DEVICES

KEY FEATURES

ISI Certified

Synonymous with trustworthiness and compliance to standards, the ISI certification on IMPACT by Honeywell Wiring Devices confirms their reliability; as well as the attention to detail that defines them.

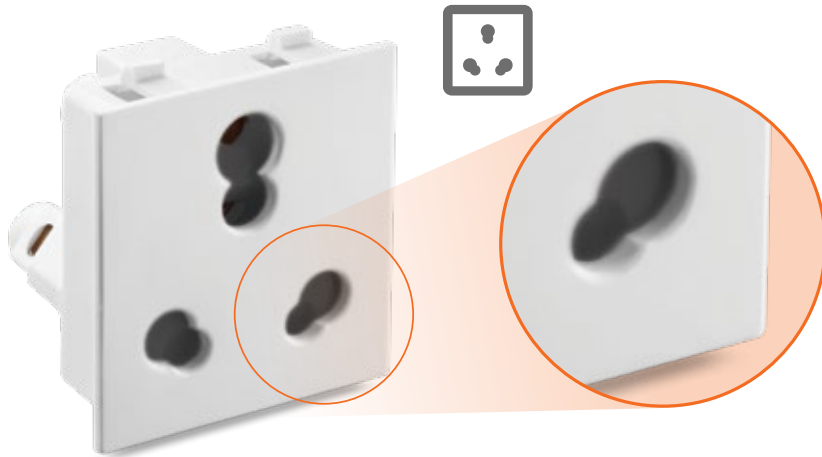

Enhanced Safety with Shuttered Sockets

The shuttered sockets of IMPACT by Honeywell Wiring Devices allow pencil free operations, and dramatically reduce the chances of accidents, whether caused by naughty toddlers or distracted adults.

Switches that Last

As your most used control mechanism, switches need to be built for endurance. The Impact by Honeywell Wiring Devices range features switches that are tested to ensure they can last up to 1 lakh operations.

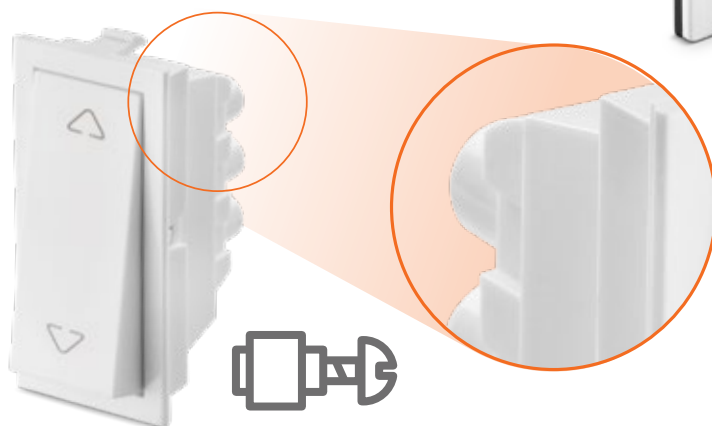

IP20 Screw Terminals

IMPACT by Honeywell Wiring Devices are equipped with IP20 screw terminals, protected from objects greater than 12 mm.

Laser Printed Markings

All markings on the IMPACT by Honeywell Wiring Devices range are laser printed; to withstand the elements and frequent use, with no change in appearance.

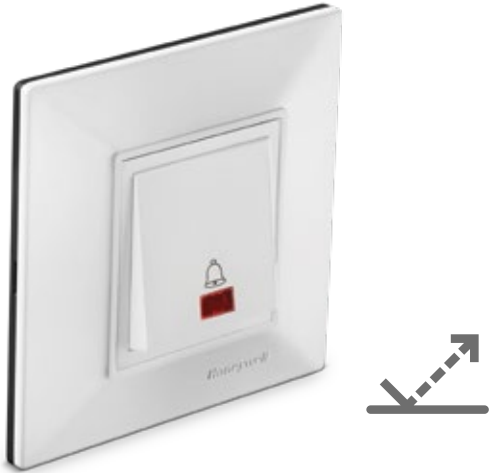
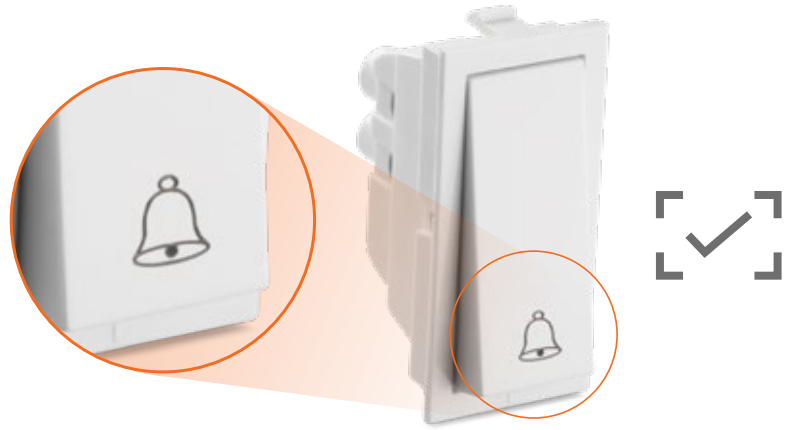

UV Stabilized

Designed to withstand years of exposure to direct sunlight, the IMPACT by Honeywell Wiring Devices range features UV stabilized finishes, for captivating good looks that last.

Chrome Highlights on Front Plates

The convenience and performance standards delivered by IMPACT by Honeywell Wiring Devices didn't come at the cost of aesthetics and visual trimmings. Our Front Plates are available both with, and without, chrome lining.



RoHS Compliant

The RoHS compliance of the IMPACT by Honeywell Wiring Devices range confirms that each product has been tested to ensure that banned substances - including Cadmium, Lead, Hexavalent Chromium, and more - cannot cause user toxicity.

IMPACT WIRING DEVICE RANGE



IW501WHI



IW502WHI



IW503WHI



IW601WHI



IW411WHI



IW412WHI



IW413WHI

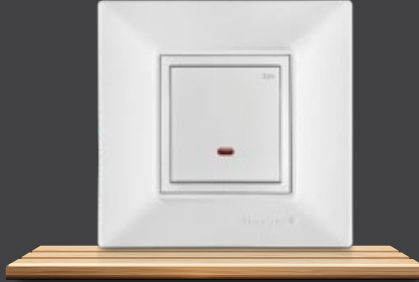

IW224WHI



IW505WHI



IW504WHI



IW421WHI



IW424WHI

Disclaimer: Representative images, products are sold individually as per Price List.



IW471WHI



IW472WHI



IW217WHI



IW227WHI



IW228WHI



IW493WHI



IW490WHI



IW441WHI



IW462WHI



IW451WHI



IW595WHI



IW586WHI

Disclaimer: Representative images, products are sold individually as per Price List.

IMPACT WIRING DEVICES

SWITCHES - WHITE

	ITEM CODE	DESCRIPTION	MODULE	CARTON QTY*
<p>IW501WHI</p> <p>IW502WHI</p> <p>IW503WHI</p> <p>IW601WHI</p> <p>IW411WHI</p> <p>IW412WHI</p> <p>IW413WHI</p> <p>IW224WHI</p> <p>IW505WHI</p> <p>IW504WHI</p>	IW501WHI	6AX One Way Switch	1M	20 / 360
	IW502WHI	6AX Two Way Switch	1M	20 / 360
	IW503WHI	6AX One Way Switch with Indicator	1M	20 / 360
	IW601WHI	6AX Two Way Switch	2M	10 / 180
	IW411WHI	16AX One Way Switch	1M	20 / 360
	IW412WHI	16AX Two Way Switch	1M	20 / 360
	IW413WHI	16AX One Way Switch with Indicator	1M	20 / 360
	IW224WHI	32A DP Switch with Indicator	2M	10 / 180
	IW505WHI	6A Bell Push Switch	1M	20 / 360
	IW504WHI	6A Bell Push Switch With Indicator	2M	10 / 180

SOCKETS - WHITE

	ITEM CODE	DESCRIPTION	MODULE	CARTON QTY*
<p>IW421WHI</p> <p>IW424WHI</p>	IW421WHI	6A Round 3Pin Socket with Shutter (ISI Marked)	2M	10 / 180
	IW424WHI	6/16A Socket (ISI Marked)	2M	10 / 180

FAN STEP CONTROLLERS - WHITE

	ITEM CODE	DESCRIPTION	MODULE	CARTON QTY*
<p>IW471WHI</p> <p>IW472WHI</p>	IW471WHI	100W 4 Step Fan Step Controller	1M	20 / 360
	IW472WHI	100W 5 Step Fan Step Controller	2M	10 / 180

Item codes with **Bold** are readily available with Honeywell. Other item codes are typically delivered within 4-8 weeks of order placement.

* Quantity inside Primary carton / Quantity inside Master carton. Orders to be placed mandatorily in multiples of quantity mentioned in **Bold**.



MINI TRIP MCB AND MOTOR STARTER - WHITE

 IW217WHI	ITEM CODE	DESCRIPTION	MODULE	CARTON QTY*
	IW217WHI	25A Motor Starter	2M	6 / 72
	IW227WHI	25A SP Minitrip MCB	1M	12 / 144
	IW228WHI	25A DP Minitrip MCB	2M	6 / 72

COMMUNICATION ACCESSORIES - WHITE

 IW493WHI	ITEM CODE	DESCRIPTION	MODULE	CARTON QTY*
	IW493WHI	RJ45 CAT6A	1M	20 / 360
	IW490WHI	RJ11 2 Line with Shutter	1M	20 / 360



SUPPORT ACCESSORIES - WHITE

 IW451WHI  IW595WHI	ITEM CODE	DESCRIPTION	MODULE	CARTON QTY*
	IW441WHI	Blank Plate	1M	40 / 720
	IW462WHI	TV Cable Outlet	1M	40 / 720
	IW451WHI	TV Coaxial Socket	1M	20 / 360
	IW595WHI	Red Neon Indicator	1M	20 / 360
	IW586WHI	2.1A 1 Port USB Charger	1M	20 / 360

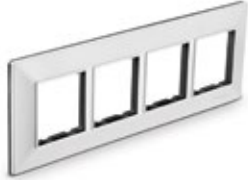

Item codes with **Bold** are readily available with Honeywell. Other item codes are typically delivered within 4-8 weeks of order placement.

* Quantity inside Primary carton / Quantity inside Master carton. Orders to be placed mandatorily in multiples of quantity mentioned in **Bold**.

FRONT PLATES - WHITE

	ITEM CODE	DESCRIPTION	MODULE	CARTON QTY*
 <p>IW101WHI</p>  <p>IW18HWHI</p>  <p>IW112WHI</p>	IW101WHI	1 Module Front Plate WHI	1M	15 / 270
	IW102WHI	2 Module Front Plate WHI	2M	15 / 270
	IW103WHI	3 Module Front Plate WHI	3M	10 / 180
	IW104WHI	4 Module Front Plate WHI	4M	10 / 180
	IW106WHI	6 Module Front Plate WHI	6M	10 / 100
	IW18HWHI	8 Module Horizontal Front Plate WHI	8M (H)	5 / 90
	IW18VWHI	8 Module Square Front Plate WHI	8M (S)	5 / 80
	IW112WHI	12 Module Front Plate WHI	12M	5 / 50
	IW116WHI	16 Module Front Plate WHI	16M	5 / 50
	IW118WHI	18 Module Front Plate WHI	18M	4 / 28

FRONT PLATES - CHROME

	ITEM CODE	DESCRIPTION	MODULE	CARTON QTY*
 <p>IW101CHR</p>  <p>IW106CHR</p>  <p>IW112CHR</p>	IW101CHR	1 Module Front Plate Chrome	1M	15 / 270
	IW102CHR	2 Module Front Plate Chrome	2M	15 / 270
	IW103CHR	3 Module Front Plate Chrome	3M	10 / 180
	IW104CHR	4 Module Front Plate Chrome	4M	10 / 180
	IW106CHR	6 Module Front Plate Chrome	6M	10 / 100
	IW18HCHR	8 Module Horizontal Front Plate Chrome	8M (H)	5 / 90
	IW18VCHR	8 Module Square Front Plate Chrome	8M (S)	5 / 80
	IW112CHR	12 Module Front Plate Chrome	12M	5 / 50
	IW116CHR	16 Module Front Plate Chrome	16M	5 / 50
	IW118CHR	18 Module Front Plate Chrome	18M	4 / 28

Item codes with **Bold** are readily available with Honeywell. Other item codes are typically delivered within 4-8 weeks of order placement.

* Quantity inside Primary carton / Quantity inside Master carton. Orders to be placed mandatorily in multiples of quantity mentioned in **Bold**.



FRONT PLATE DIMENSIONS

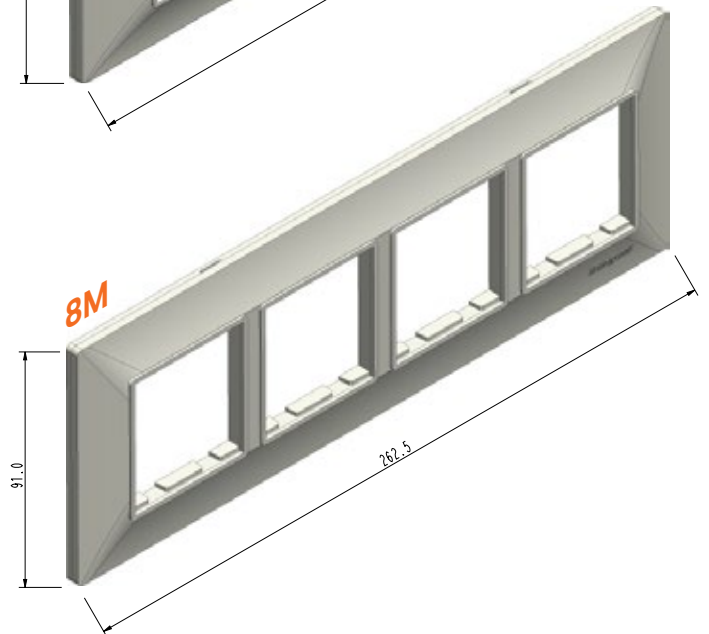
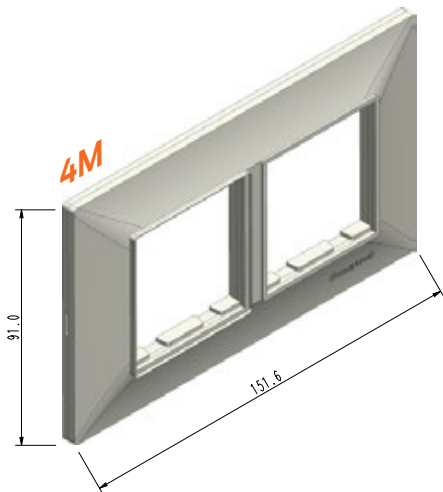
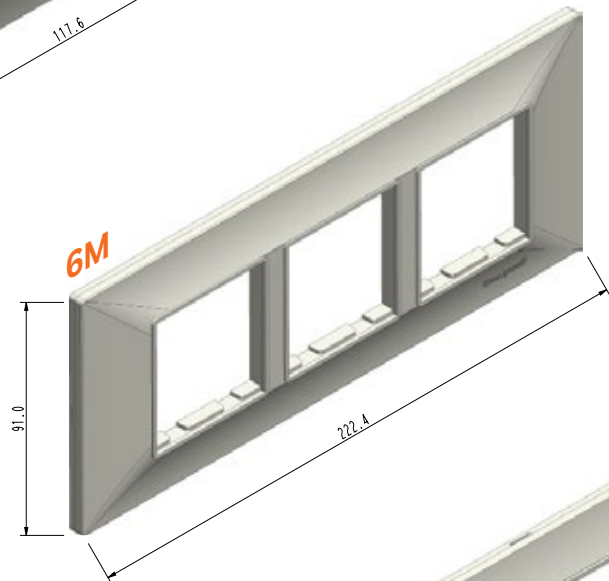
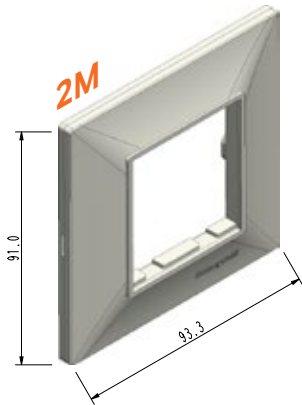
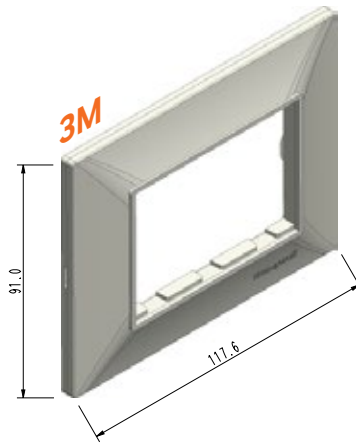
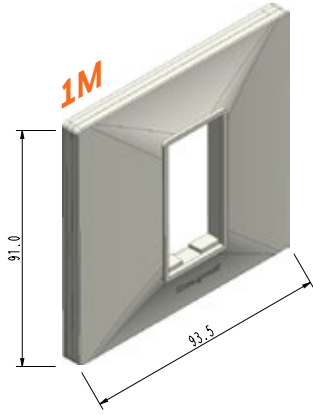

FRONT PLATES - WHITE & CHROME

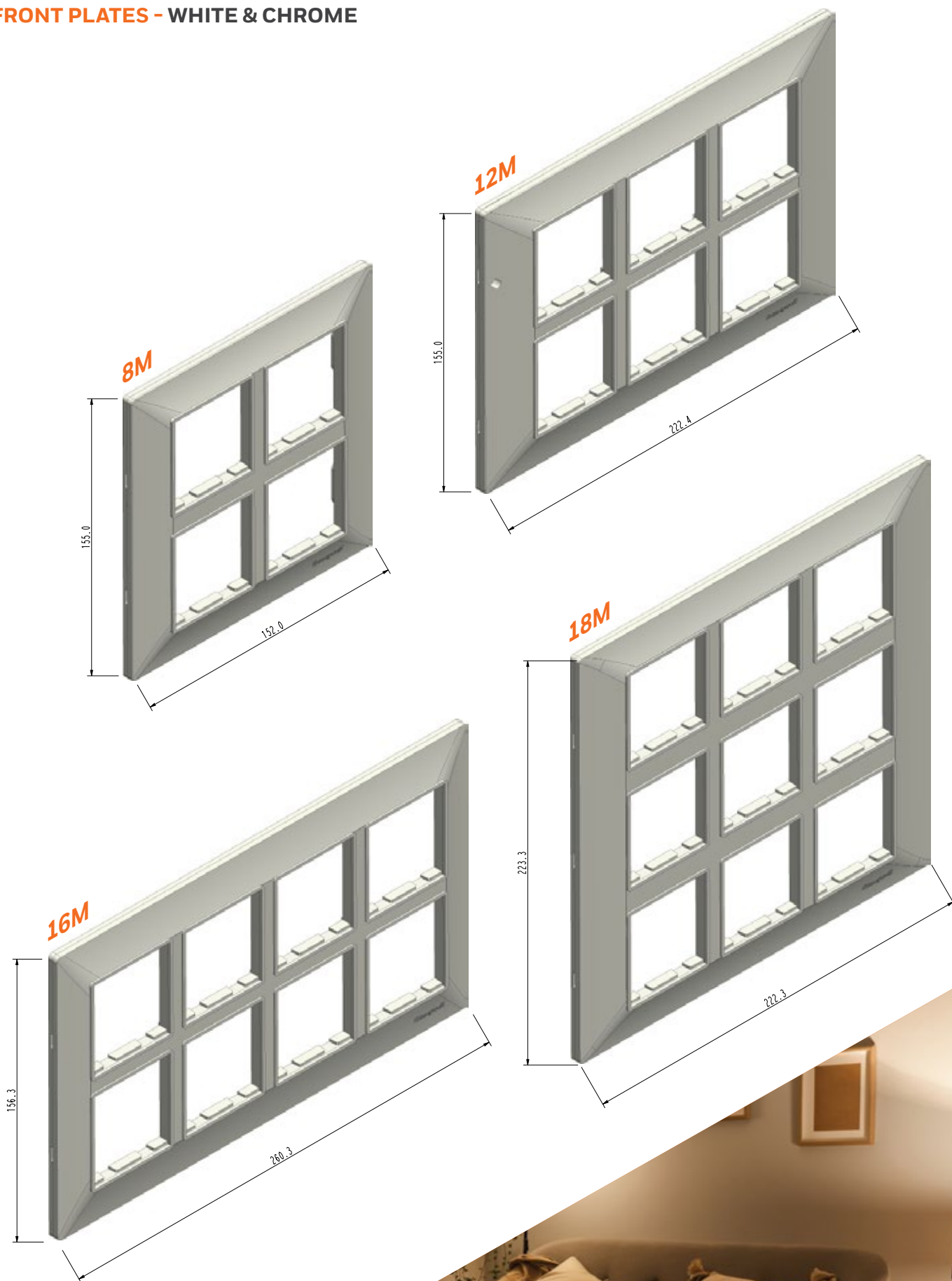

SLEEK LOOKS AND INNOVATIVE FEATURES TO COMPLEMENT THE MODERN HOME

State-of-the-art wiring devices, for future-ready user-experiences and effortless style



FOR SPACES THAT BUILD YOUR DREAMS WITH CONFIDENCE

Presenting

Circuit Protection Range



Get the freedom to
build your dreams
with safety

Improper wiring or overloads can cause electrical hazards. Our Circuit Protection range interrupts the current flow if needed and shuts down power to protect electrical equipment. Now your dreams have a safe space to grow.

Key features :



10kA
short-circuit
breaking capacity



IP20 captive
screw
terminals



35 sqmm
terminal
size



Bi-connect
terminals



Air vent
channels



Fast trip
mechanism



Dual position
DIN clip

Get in touch for more details

BARODA

Ground Floor, 1965,
Alembic City Avenue,
Alembic Campus, Alembic Road,
Vadodara - 390 003

HYDERABAD

8-2-418, Krishnama House,
3rd Floor, Road No. 7,
Banjara Hills,
Hyderabad - 500 034

BENGALURU

Honeywell Camp II,
Bldgs 9A & 9B, Plot C2, RMZ Ecoworld,
Varturhobli, Sarjapur Marathahalli,
Outer Ring Road,
Bengaluru - 560 103

KOLKATA

Unit Number-1205, 12th Floor,
Godrej Waterside Tower-2,
DP Block, Sector-V, Salt Lake,
Kolkata - 700 091

CHENNAI

5th, 6th & 7th Floor,
KRM Plaza, North Tower,
#2 Harrington Road, Chetpet,
Chennai - 600 031

MUMBAI

WeWork Chromium,
6th floor. Milind Nagar,
Opp. L&T Flyover,
JVLR, Powai,
Mumbai - 400 076

GURUGRAM

Unitech Trade Center,
Sector 43, Block C,
Sushant Lok, Phase 1,
Gurgaon - 122 022

PUNE

Plot No. 56/57,
Hadapsar Industrial Estate,
Pune - 411 013

**FOR FURTHER DETAILS,
PLEASE REACH US AT :**

Toll Free Number: 1800-103-3848

Monday to Sunday: 10AM - 7PM

Whatsapp: +91 81306-91299

Email: eesteamindia@honeywell.com

Website: www.honeywellbuildings.in/electrical-products

WIRING DEVICES PRICE LIST | 01 | 04/22
© 2022 Honeywell International Inc.

IMPACT

by Honeywell